



Fleck 1500

Service Manual

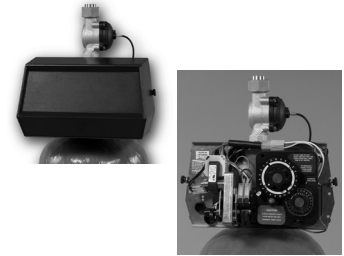

TABLE OF CONTENTS

JOB SPECIFICATION SHEET	1
INSTALLATION	2
START-UP INSTRUCTIONS	2
3200 TIMER SETTING PROCEDURE	3
3210 TIMER SETTING PROCEDURE	4
3200, 3210, 3220, 3230 REGENERATION CYCLE SETTING PROCEDURE	5
3200 TIMER ASSEMBLY	6
3210 TIMER ASSEMBLY	7
POWERHEAD ASSEMBLY (DESIGNER)	8
POWERHEAD ASSEMBLY (ENVIRONMENTAL)	9
MANUAL POWERHEAD ASSEMBLY	10
CONTROL VALVE ASSEMBLY	11
SOFTENER & FILTER CONVERSION KITS	12
METER ASSEMBLY	13
1600 BRINE SYSTEM	14
1650 BRINE SYSTEM	15
2300 SAFETY BRINE VALVE	16
2310 SAFETY BRINE VALVE	17
SEAL & SPACER TOOLS & REPLACEMENT	18
GENERAL SERVICE HINTS FOR METER CONTROL	19
TROUBLESHOOTING	20
WATER CONDITIONER FLOW DIAGRAMS	21
FLOW DATA & INJECTOR DRAW RATES	22
PLUMBING DIAGRAM: TYPICAL TOP MOUNTING INSTALLATION	23
WIRING DIAGRAM	24
SERVICE ASSEMBLIES	25

JOB SPECIFICATION SHEET

Job Number: _____
 Model Number: _____
 Water Hardness: _____ ppm or gpg
 Capacity Per Unit: _____
 Mineral Tank Size: _____ Diameter: _____ Height: _____
 Salt Setting per Regeneration: _____

1. Type of Timer:

- A. 7 Day or 12 Day
- B. Meter Initiated

2. Downflow: Upflow Upflow Variable

3. Meter Size:

- A. 3/4" Std Range (125 - 2,100 gallon setting)
- B. 3/4" Ext Range (625 - 10,625 gallon setting)
- C. 1" Std Range (310 - 5,270 gallon setting)
- D. 1" Ext Range (1,150 - 26,350 gallon setting)
- E. 1-1/2" Std Range (625 - 10,625 gallon setting)
- F. 1-1/2" Ext Range (3,125 - 53,125 gallon setting)
- G. 2" Std Range (1,250 - 21,250 gallon setting)
- H. 2" Ext Range (6,250 - 106,250 gallon setting)
- I. 3" Std Range (3,750 - 63,750 gallon setting)
- J. 3" Ext Range (18,750 - 318,750 gallon setting)
- K. Electronic _____ Pulse Count _____ Meter Size _____

4. System Type:

- A. System #4: 1 Tank, 1 Meter, Immediate, or Delayed Regeneration
- B. System #4: Time Clock
- C. System #4: Twin Tank
- D. System #5: 2-5 Tanks, 2 Meters, Interlock
- E. System #6: 2-5 Tanks, 1 Meter, Series Regeneration
- F. System #7: 2-5 Tanks, 1 Meter, Alternating
- G. System #9: Electronic Only, 2-4 Tanks, Meter per Valve, Alternating
- H. System #14: Electronic Only, 2-4 Tanks, Meter per Valve. Brings units on and offline based on flow.

5. Timer Program Settings:

- A. Backwash: _____ Minutes
- B. Brine and Slow Rinse: _____ Minutes
- C. Rapid Rinse: _____ Minutes
- D. Brine Tank Refill: _____ Minutes
- E. Pause Time: _____ Minutes
- F. Second Backwash: _____ Minutes

6. Drain Line Flow Control: _____ gpm

7. Brine Line Flow Controller: _____ gpm

8. Injector Size#: _____

9. Piston Type:

- A. Hard Water Bypass
- B. No Hard Water Bypass

INSTALLATION

Water Pressure

A minimum of 20 pounds (1.4 bar) of water pressure is required for regeneration valve to operate effectively.

Electrical Facilities

An uninterrupted alternating current (A/C) supply is required. Note: Other voltages are available. Please make sure your voltage supply is compatible with your unit before installation.

Existing Plumbing

Condition of existing plumbing should be free from lime and iron buildup. Piping that is built up heavily with lime and/or iron should be replaced. If piping is clogged with iron, a separate iron filter unit should be installed ahead of the water softener.

Location Of Softener And Drain

The softener should be located close to a drain to prevent air breaks and back flow.

By-Pass Valves

Always provide for the installation of a by-pass valve if unit is not equipped with one.

CAUTION Water pressure is not to exceed 125 psi (8.6 bar), water temperature is not to exceed 110°F (43°C), and the unit cannot be subjected to freezing conditions.

Installation Instructions

1. Place the softener tank where you want to install the unit making sure the unit is level and on a firm base.
2. During cold weather, the installer should warm the valve to room temperature before operating.
3. All plumbing should be done in accordance with local plumbing codes. The pipe size for residential drain line should be a minimum of 1/2" (13 mm). Backwash flow rates in excess of 7 gpm (26.5 Lpm) or length in excess of 20' (6 m) require 3/4" (19 mm) drain line. Commercial drain lines should be the same size as the drain line flow control.
4. Refer to the dimensional drawing for cutting height of the distributor tube. If there is no dimensional drawing, cut the distributor tube flush with the top of the tank.
5. Lubricate the distributor O-ring seal and tank O-ring seal. Place the main control valve on tank. Note: Only use silicone lubricant.
6. Solder joints near the drain must be done prior to connecting the Drain Line Flow Control fitting (DLFC). Leave at least 6" (15 cm) between the DLFC and solder joints when soldering pipes that are connected on the DLFC. Failure to do this could cause interior damage to the DLFC.
7. Teflon tape is the only sealant to be used on the drain fitting. The drain from twin tank units may be run through a common line.
8. Make sure that the floor is clean beneath the salt storage tank and that it is level.
9. Place approximately 1" (25 mm) of water above the grid plate. If a grid is not utilized, fill to the top of the air check (Figure 1) in the salt tank. Do not add salt to the brine tank at this time.
10. On units with a by-pass, place in by-pass position. Turn on the main water supply. Open a cold soft water tap nearby and let run a few minutes or until the system is free from foreign material (usually solder) that may have resulted from the installation. Once clean, close the water tap.

11. Slowly place the by-pass in service position and let water flow into the mineral tank. When water flow stops, slowly open a cold water tap nearby and let run until the air is purged from the unit.
12. Plug unit into an electrical outlet. Note: All electrical connections must be connected according to local codes. Be certain the outlet is uninterrupted.

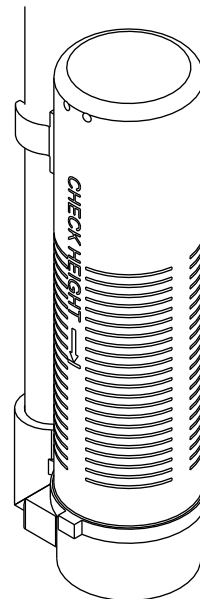

60002 Rev E

Figure 1 Residential Air Check Valve

START-UP INSTRUCTIONS

The water softener should be installed with the inlet, outlet, and drain connections made in accordance with the manufacturer's recommendations, and to meet applicable plumbing codes.

1. Turn the manual regeneration knob slowly in a clockwise direction until the program micro switch lifts on top of the first set of pins. Allow the drive motor to move the piston to the first regeneration step and stop. Each time the program switch position changes, the valve will advance to the next regeneration step. Always allow the motor to stop before moving to the next set of pins or spaces.
- NOTE: For electronic valves, please refer to the manual regeneration part of the timer operation section. If the valve came with a separate electronic timer service manual, refer to the timer operation section of the electronic timer service manual.**
2. Position the valve to backwash. Ensure the drain line flow remains steady for 10 minutes or until the water runs clear (see above).
 3. Position the valve to the brine / slow rinse position. Ensure the unit is drawing water from the brine tank (this step may need to be repeated).
 4. Position the valve to the rapid rinse position. Check the drain line flow, and run for 5 minutes or until the water runs clear.
 5. Position the valve to the start of the brine tank fill cycle. Ensure water goes into the brine tank at the desired rate. The brine valve drive cam will hold the valve in this position to fill the brine tank for the first regeneration.
 6. Replace control box cover.
 7. Put salt in the brine tank.

NOTE: Do not use granulated or rock salt.

3200 TIMER SETTING PROCEDURE

How To Set Days On Which Water Conditioner Is To Regenerate (Figure 2)

Rotate the skipper wheel until the number "1" is at the red pointer. Set the days that regeneration is to occur by sliding tabs on the skipper wheel outward to expose trip fingers. Each tab is one day. Finger at red pointer is tonight. Moving clockwise from the red pointer, extend or retract fingers to obtain the desired regeneration schedule.

How To Set The Time Of Day

1. Press and hold the red button in to disengage the drive gear.
2. Turn the large gear until the actual time of day is at the time of day pointer.
3. Release the red button to again engage the drive gear.

How To Manually Regenerate Your Water Conditioner At Any Time

1. Turn the manual regeneration knob clockwise.
2. This slight movement of the manual regeneration knob engages the program wheel and starts the regeneration program.
3. The black center knob will make one revolution in the following approximately three hours and stop in the position shown in the drawing.
4. Even though it takes three hours for this center knob to complete one revolution, the regeneration cycle of your unit might be set for only one half of this time.
5. In any event, conditioned water may be drawn after rinse water stops flowing from the water conditioner drain line.

How to Adjust Regeneration Time

1. Disconnect the power source.
2. Locate the three screws behind the manual regeneration knob by pushing the red button in and rotating the 24 hour dial until each screw appears in the cut out portion of the manual regeneration knob.
3. Loosen each screw slightly to release the pressure on the time plate from the 24 hour gear.
4. Locate the regeneration time pointer on the inside of the 24 hour dial in the cut out.
5. Turn the time plate so the desired regeneration time aligns next to the raised arrow.
6. Push the red button in and rotate the 24 hour dial. Tighten each of the three screws.
7. Push the red button and locate the pointer one more time to ensure the desired regeneration time is correct.
8. Reset the time of day and restore power to the unit.

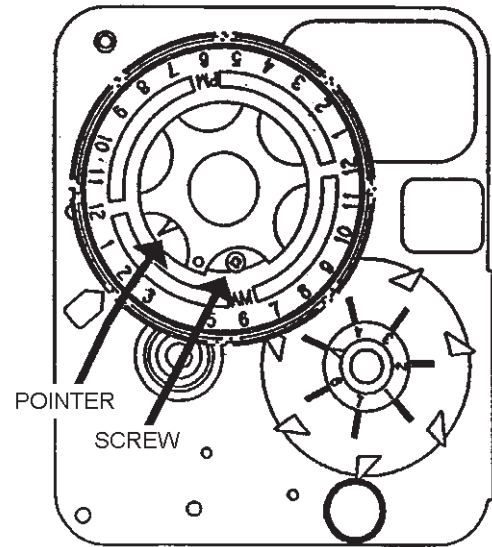
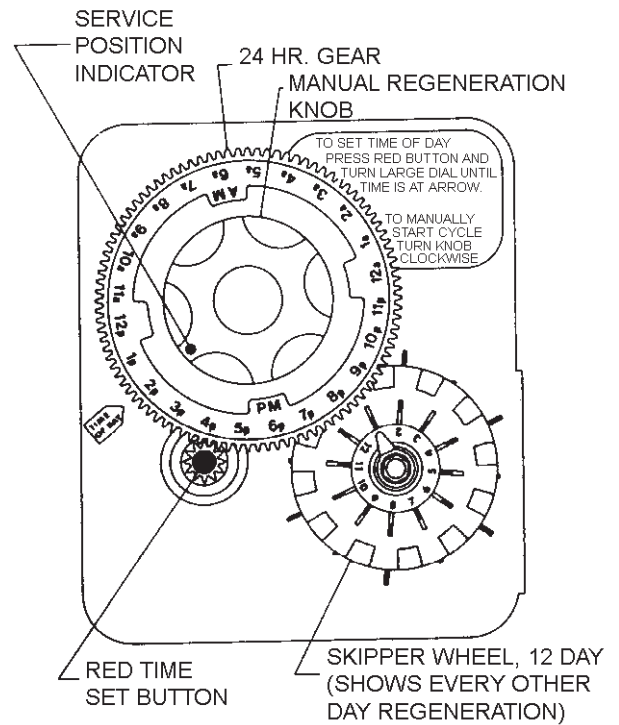

3200 ADJUSTABLE REGENERATION TIMER

IMPORTANT!
SALT LEVEL MUST ALWAYS BE ABOVE
WATER LEVEL IN BRINE TANK

61502-3200 Rev A

Figure 2

3210 TIMER SETTING PROCEDURE

Typical Programming Procedure

Calculate the gallon capacity of the system, subtract the necessary reserve requirement and set the gallons available opposite the small white dot on the program wheel gear (Figure 3).

NOTE: Drawing shows 8,750 gallon setting. The capacity (gallons) arrow (15) shows zero gallons remaining. The unit will regenerate tonight at the set regeneration time.

How To Set The Time Of Day

1. Press and hold the red button in to disengage the drive gear.
2. Turn the large gear until the actual time of day is opposite the time of day pointer.
3. Release the red button to again engage the drive gear.

How To Manually Regenerate Your Water Conditioner At Any Time

1. Turn the manual regeneration knob clockwise.
2. This slight movement of the manual regeneration knob engages the program wheel and starts the regeneration program.
3. The black center knob will make one revolution in the following approximately three hours and stop in the position shown in the drawing.
4. Even though it takes three hours for this center knob to complete one revolution, the regeneration cycle of your unit might be set for only one half of this time.
5. In any event, conditioned water may be drawn after rinse water stops flowing from the water conditioner drain line.

Immediate Regeneration Timers

These timers do not have a 24 hour gear. Setting the gallons on the program wheel and manual regeneration procedure are the same as previous instructions. The timer will regenerate as soon as the capacity gallons reaches zero.

NOTE: The program wheel to the left may be different than the program wheel on the product.

NOTE: To set meter capacity rotate manual knob one - 360° revolution to set gallonage.

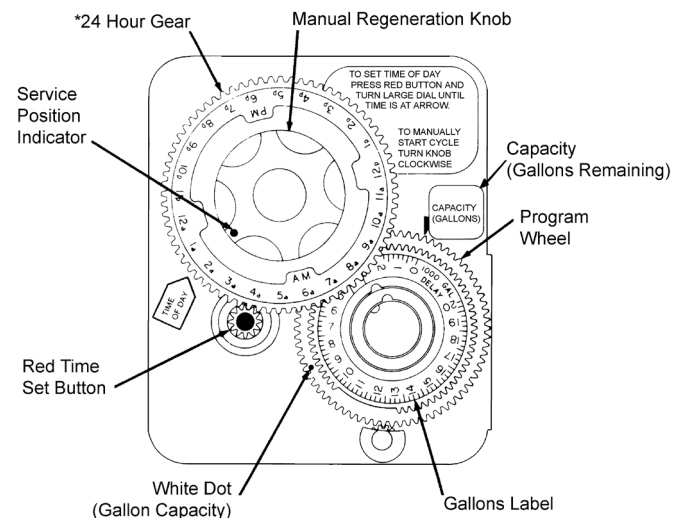

*Immediate regeneration timers do not have a 24-hour gear. No time of day can be set.

61502-3200 Rev A

Figure 3

3200, 3210, 3220, 3230 REGENERATION CYCLE SETTING PROCEDURE

How To Set The Regeneration Cycle Program

The regeneration cycle program on your water conditioner has been factory preset, however, portions of the cycle or program may be lengthened or shortened in time to suit local conditions.

3200 Series Timers (Figure 4)

1. To expose cycle program wheel, grasp timer in upper left-hand corner and pull, releasing snap retainer and swinging timer to the right.
2. To change the regeneration cycle program, the program wheel must be removed. Grasp program wheel and squeeze protruding lugs toward center, lift program wheel off timer. Switch arms may require movement to facilitate removal.
3. Return timer to closed position engaging snap retainer in back plate. Make certain all electrical wires locate above snap retainer post.

Timer Setting Procedure

How To Change The Length Of The Backwash Time

The program wheel as shown in the drawing is in the service position. As you look at the numbered side of the program wheel, the group of pins starting at zero determines the length of time your unit will backwash.

For example, if there are six pins in this section, the time of backwash will be 12 min. (2 min. per pin). To change the length of backwash time, add or remove pins as required. The number of pins times two equals the backwash time in minutes.

How To Change The Length Of Brine And Rinse Time

1. The group of holes between the last pin in the backwash section and the second group of pins determines the length of time that your unit will brine and rinse (2 min. per hole).
2. To change the length of brine and rinse time, move the rapid rinse group of pins to give more or fewer holes in the brine and rinse section. Number of holes times two equals brine and rinse time in minutes.

How To Change The Length Of Rapid Rinse

1. The second group of pins on the program wheel determines the length of time that your water conditioner will rapid rinse (2 min. per pin).
2. To change the length of rapid rinse time, add or remove pins at the higher numbered end of this section as required. The number of pins times two equals the rapid rinse time in minutes.

How To Change The Length Of Brine Tank Refill Time

1. The second group of holes in the program wheel determines the length of time that your water conditioner will refill the brine tank (2 min. per hole).
2. To change the length of refill time, move the two pins at the end of the second group of holes as required.
3. The regeneration cycle is complete when the outer microswitch is tripped by the two pin set at end of the brine tank refill section.
4. The program wheel, however, will continue to rotate until the inner micro switch drops into the notch on the program wheel.

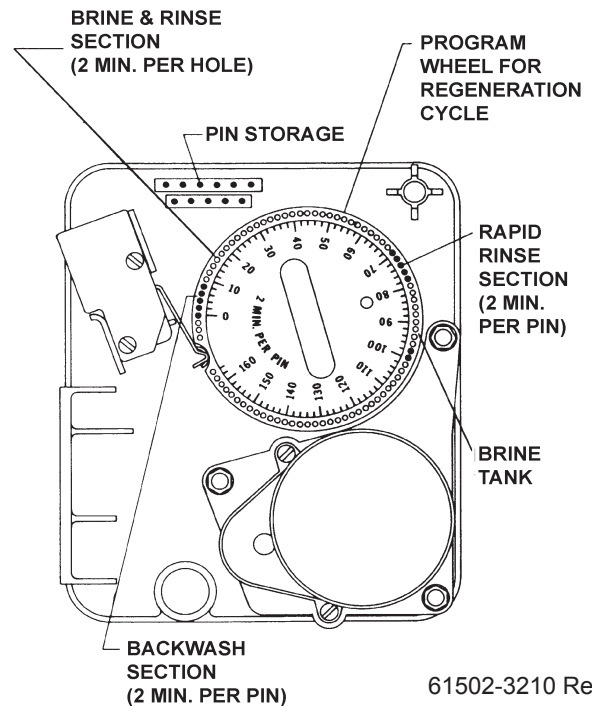
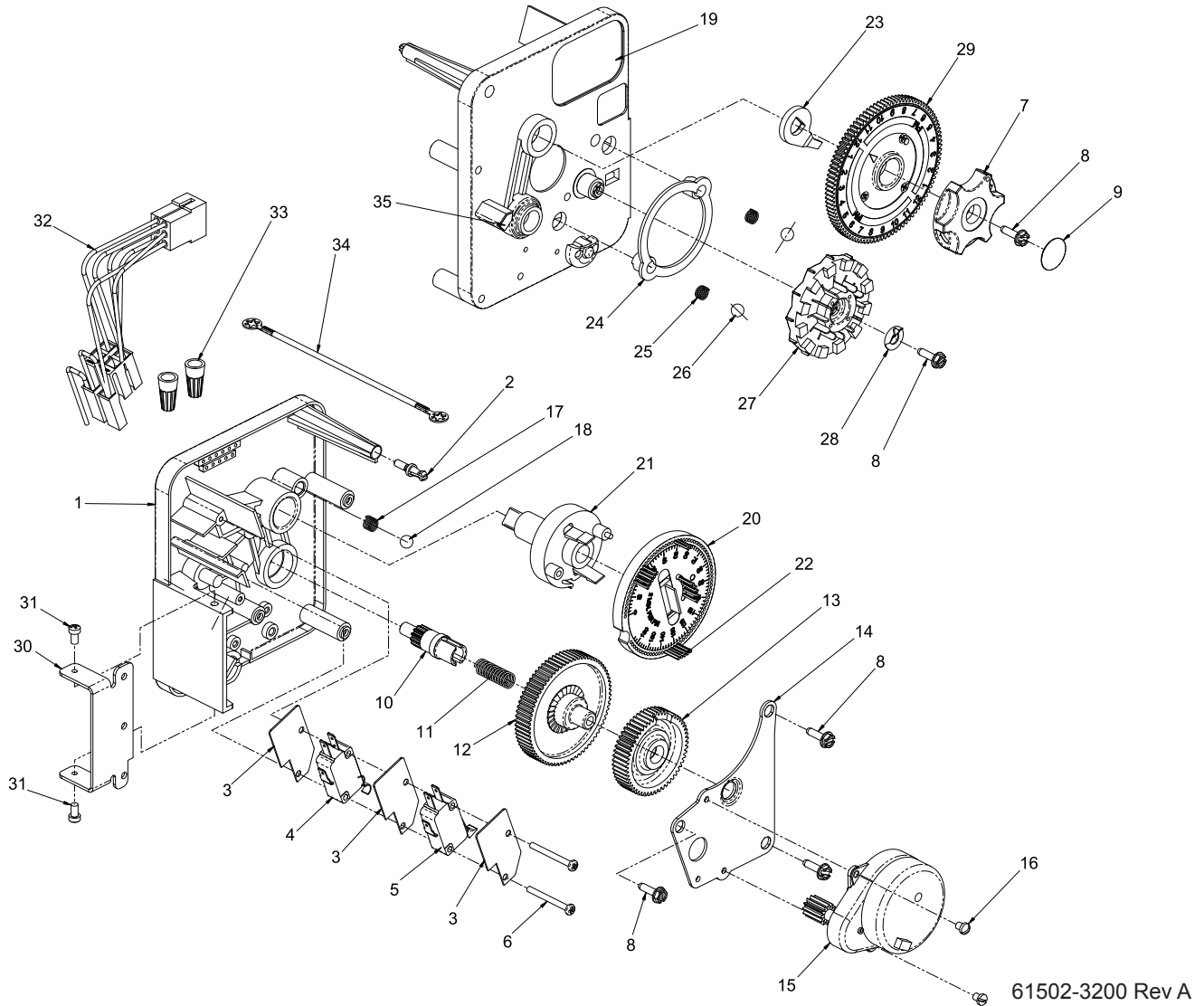

Figure 4

3200 TIMER ASSEMBLY



61502-3200 Rev A

Item No.	QTY	Part No.	Description
1	1	13870	Housing, Timer, 3200
2	1	14265	Clip, Spring
3	3	14087	Insulator
4	1	10896	Switch, Micro
5	1	15320	Switch, Micro, Timer
6	2	11413	Screw, Pan Hd Mach, 4-40 x 1-1/8
7	1	13886	Knob, 3200
8	5	13296	Screw, Hex Wsh, 6-20 x 1/2
9	1	11999	Label, Button
10	1	13018	Pinion, Idler
11	1	13312	Spring, Idler Shaft
12	1	13017	Gear, Idler
13	1	13164	Gear, Drive
14	1	13887	Plate, Motor Mounting
15	1	18743-1	Motor, 120V, 60Hz, 1/30 RPM, 5600
	1	19659-1	Motor, 24V, 60Hz, 1/30 RPM
16	2	13278	Screw, Slt'd Fillister Hd 6-32 x .156
17	1	15424	Spring, Detent, Timer

Item No.	QTY	Part No.	Description
18	1	15066	Ball, 1/4", Delrin
19	1	15465	Label, Caution
20	1	19210	Program Wheel Assy
21	1	13911	Gear, Main Drive, Timer
22	17	41754	Pin, Spring, 1/16 x 5/8 SS, Timer
23	1	13011	Arm, Cycle Actuator
24	1	13864	Ring, Skipper Wheel
25	2	13311	Spring, Detent, Timer
26	2	13300	Ball, 1/4", SS
27	1	14381	Skipper Wheel Assy, 12 Day
	1	14860	Skipper Wheel Assy, 7 Day
28	1	13014	Pointer, Regeneration
29	1	40096-24	Dial, 12 AM Regen Assy, Black
	1	40096-02	Dial, 2 AM Regen Assy, Black
30	1	13881	Bracket, Hinger Timer
31	2	11384	Screw, Phil, 6-32 x 1/4 Zinc
32	1	13902	Harness, 3200
33	2	40422	Nut, Wire, Tan
34	1	15354-01	Wire, Ground, 4"
35	1	14007	Label, Time of Day

3210 TIMER ASSEMBLY

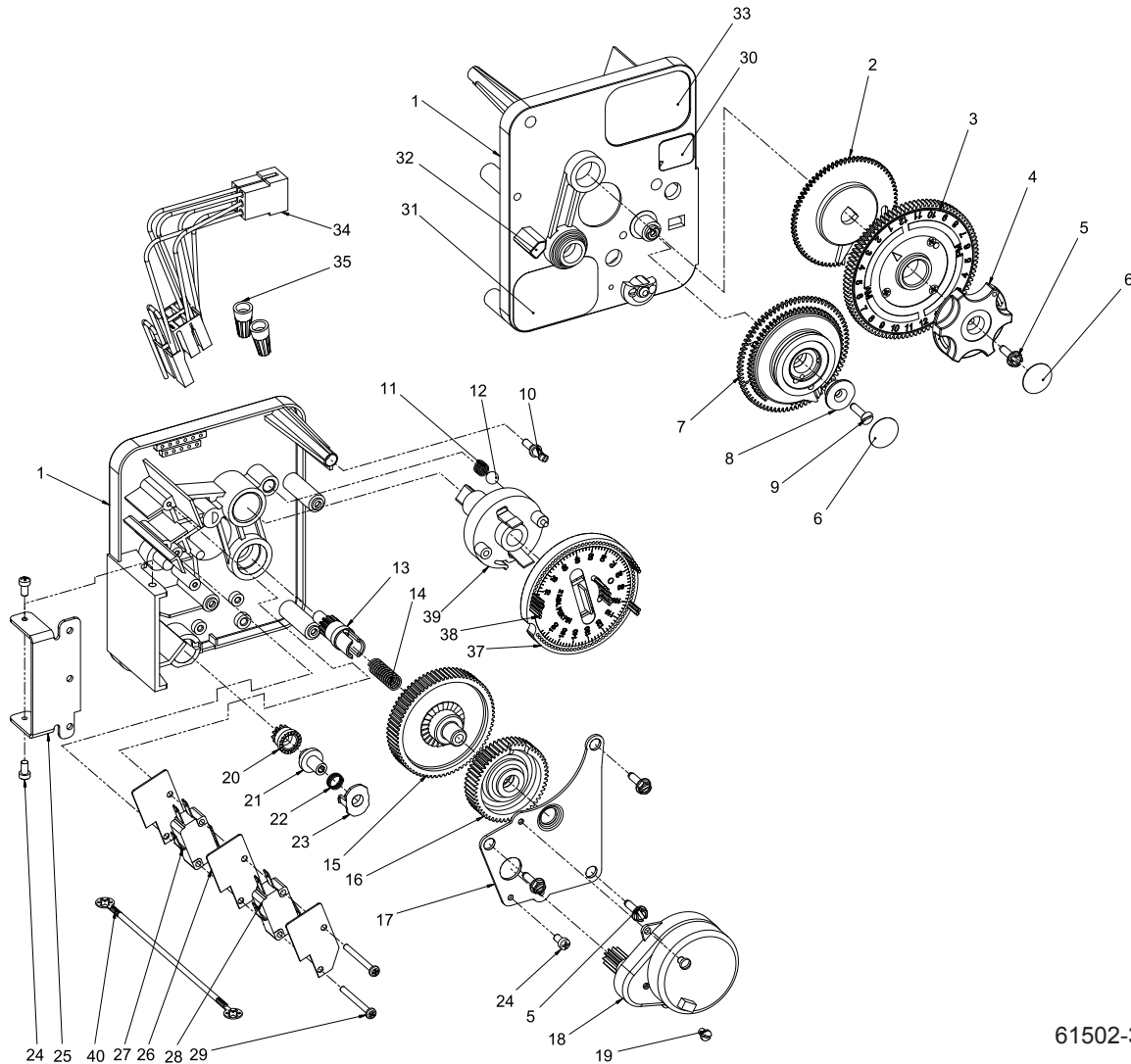

61502-3210 Rev A

Item No.	QTY	Part No.	Description	Item No.	QTY	Part No.	Description
1	1	13870	Housing, Timer, 3200	21	1	13831	Clutch, Drive Pinion
2	1	13802	Gear, Cycle Actuator	22	1	14276	Spring, Meter, Clutch
3	1	40096-02	Dial 2 AM Regen Assy, Black	23	1	14253	Retainer, Clutch Spring
4	1	13886	Knob, 3200	24	3	11384	Screw, Phil, 6-32 x 1/4
5	4	13296	Screw, Hex Wsh, 6-20 x 1/2	25	1	13881	Bracket, Hinge Timer
6	2	11999	Label, Button	26	3	14087	Insulator
7	1	60405-15	Program Wheel, w/34" Std Label, w/People Label Set @ 21	27	1	10896	Switch, Micro
8	1	13806	Retainer, Program Wheel	28	1	15320	Switch, Micro, Timer
9	1	13748	Screw, Flat Head St, 6-20 x 1/2	29	2	11413	Screw, Pan Hd Mach, 4-40 x 1/8
10	1	14265	Clip, Spring	30	1	14198	Label, Indicator
11	1	15424	Spring, Detent, Timer	31	1	15465	Label, Caution
12	1	15066	Ball, 1/4" Delrin	32	1	14007	Label, Time of Day
13	1	13018	Pinion, Idler	33	1	14045	Label, Instruction
14	1	13312	Spring, Idler Shaft	34	1	13902	Harness, 3200
15	1	13017	Gear, Idler	35	2	40422	Nut, Wire, Tan
16	1	13164	Gear, Drive	36	1	15354-01	Wire, Ground, 4"
17	1	13887	Plate, Motor Mounting	37	1	19210	Program Wheel Assy
18	1	18743-1	Motor, 120V, 60Hz 1/30 RPM, 5600	38	17	41754	Pin, Spring, 1/16 x 5/8 SS, Timer
19	1	13278	Screw, Fillister Hd, 6-32 x .156	39	1	13911	Gear, Main Drive, Timer
20	1	13830	Pinion, Program Wheel Drive	40	1	15354-01	Wire, Ground 4"

POWERHEAD ASSEMBLY (DESIGNER)

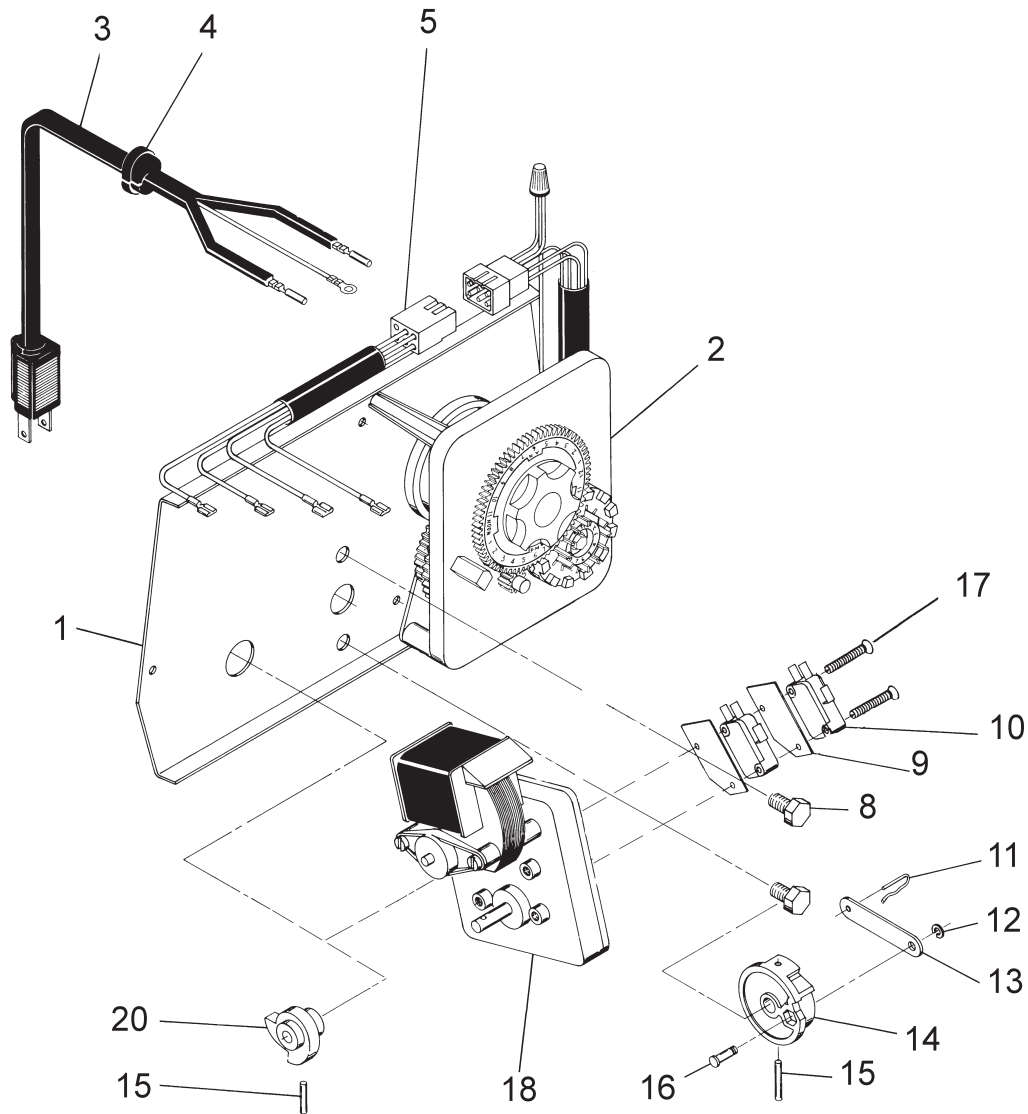

61502_2510 Rev B

Item No.	QTY	Part No.	Description
1.....	1	40264	Backplate, SS/Service Valve Operator, W-T-Screws
2.....	1		3200, Timer 7 or 12 Day
3.....	1	11838	Power Cord
4.....	1	13547	Strain Relief
5.....	1	40400	Harness, Drive, Designer/ Environmental
8.....	2	10231	Screw - Drive Mounting
9.....	2	10302	Insulator
10.....	2	10218	Switch
11.....	1	10909	Connecting Link Pin
12.....	1	10250	Retaining Ring
13.....	1	10621	Connecting Link
14.....	1	12576	Drive Cam - STF (Black)
15.....	2	10338	Roll Pin
16.....	1	13366	Drive Bearing
17.....	2	14923	Screw - Switch Mounting

Item No.	QTY	Part No.	Description
18.....	1	41543*	Motor, Drive, 115V, 50/60Hz
		42579**	Motor, Drive, 24VAC/VDC, 50/60Hz
		41545*	Motor, Drive, 230V, 50/60Hz
20.....	1	12777	Brine Valve Cam - Separate Time Fill (Black)

Not Shown:

2	10300	Screw - Timer Mounting
1	13741	Hole Plug
1	17904	Hole Plug
2	19367	Screw, Thumb
1	15625	Cable Guide Assy, 3/4"
1	14730	Meter Cable, 13"
1	60232-110	Cover, Designer, 1 Pc. Black

* Bracket is integrated into the motor.

** Bracket is integrated into the motor and picture may not reflect actual component.

Motor drawing may not resemble actual.

For Service Assembly Numbers, See the Back of this Manual

MANUAL POWERHEAD ASSEMBLY

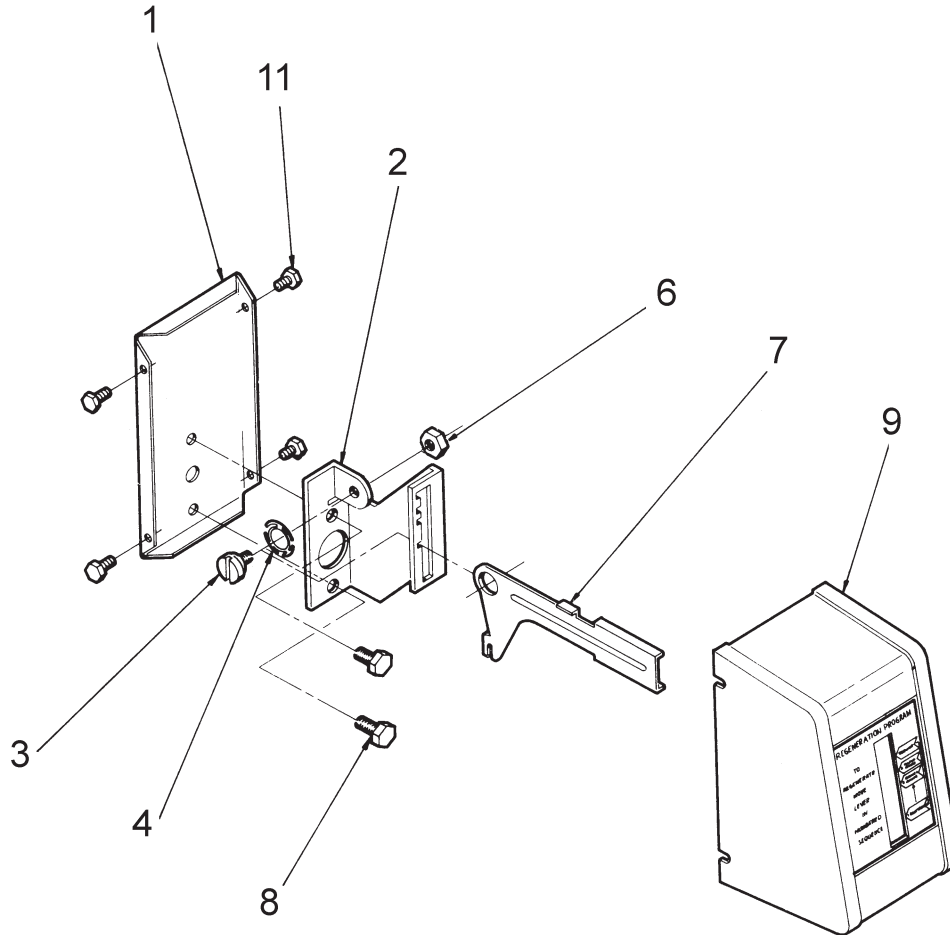

60409 Rev A

Item No.	QTY	Part No.	Description
1.....	1	12593.....	Backplate, Manual
2.....	1	12592.....	Bracket, Lever Position
3.....	1	12596.....	Screw, Spec Mach, 1/4 - 20 x 1/2
4.....	1	12707.....	Washer, Spring
6.....	1	11235	Nut, Hex, 1/4 - 20, Mach Screw, Zinc
7.....	1	12594.....	Lever, Valve Position
8.....	2	10231.....	Screw, Slot Hex, 1/4 - 20 x 1/2 18-8 SS
9.....	1	60224-32.....	Cover Assy, Manual, Filter
	1	60224-33.....	Cover Assy, Manual, Softener
11.....	4	10300.....	Screw, Slot Hex Wsh, 8-18 x 3/8 Type "B" RC44-47

Not Shown:

1	10909.....	Pin, Link
---------	------------	-----------

For Service Assembly Numbers, See the Back of this Manual

CONTROL VALVE ASSEMBLY

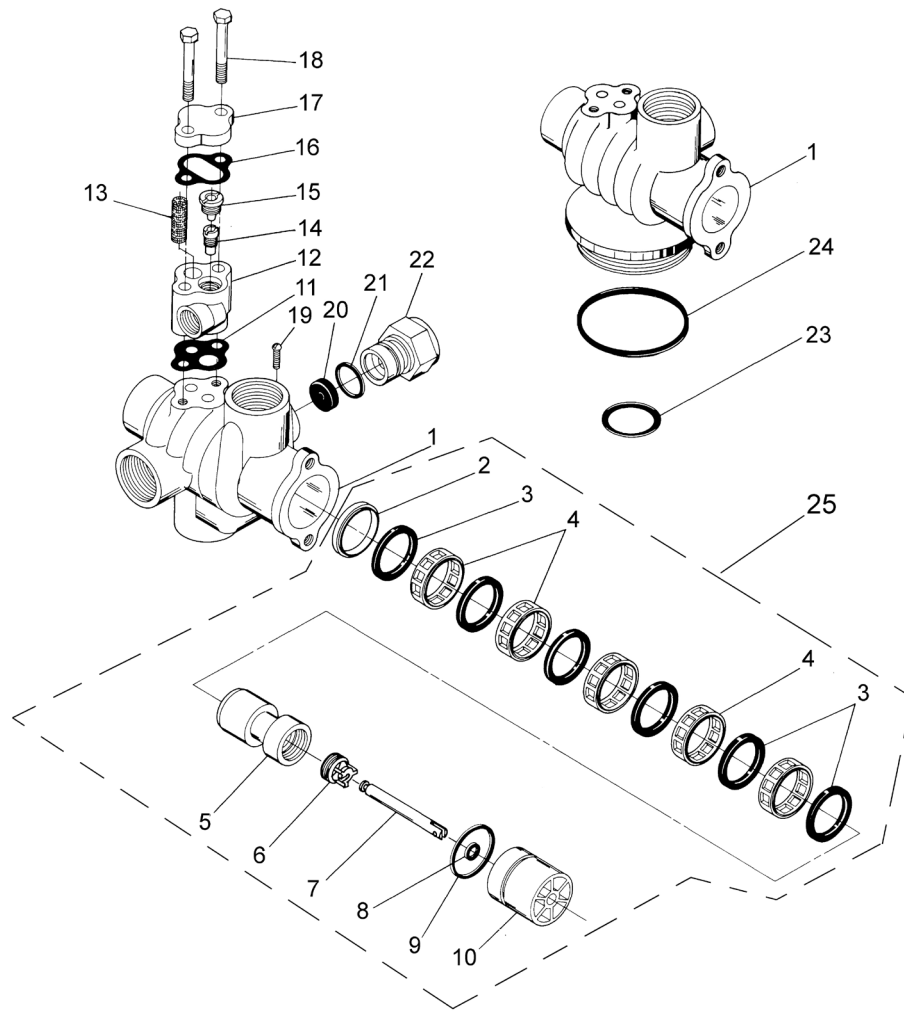

61500-1500 Rev B

Item No.	QTY	Part No.	Description
1.....	1	10729	Valve Body, 1500, Sm
.....	1	10680	Valve Body, 1500
2.....	1	10757b	Spacer, End, Brass
3.....	6	10545	Seal, Piston, 560CD
4.....	5	16589	Spacer, HW
5.....	1	15168	Piston
6.....	1	16590	Piston Rod Retainer, Hot Water
7.....	1	14452	Piston Rod
8.....	1	10209-01	Quad Ring, -010,560CD
9.....	1	10234-01	O-ring, -024,560CD
10.....	1	10598-01	End Plug Assembly, Hot Water
11.....	1	14805	Gasket,injector Body,1600/1700
12.....	1	17776	Body, Injector, 1600
.....	1	11483	Body, Injector, Brass
13.....	1	10227	Screen, Injector
14.....	1	10914-xx	Throat, Injector (Specify Size)
.....	1	10226-xx	Throat, Injector, SS (Specify Size)
15.....	1	10913-xx	Injector Nozzle (Specify Size)
.....	1	10225	Nozzle, Injector, SS (Specify Size)
16.....	1	10229	Gasket, Injector Cap, 1600
17.....	1	10228	Cap, Injector, Brass

Item No.	QTY	Part No.	Description
.....	1	11893	Cap, Injector, Stainless Steel
18.....	1	10692	Screw, Slot Hex Hd, 10-24 X 18-8S
19.....	1	11180	Screw, Rd Hd Mach, 6-32 X 1/2
20.....	1		Flow Control Washer (Specify Flow Rate In GPM)
21.....	1	11183	O-ring, -017
22.....	1	60705-00	Dlfc, Plastic, Blank
.....	1	11385-03	Housing, Flow Control, Brass
.....	1	11385-13	Dlfc, Brass Bored
23.....	1	10244	O-ring, -211
24.....	1	12570	O-ring, Park Tank, 1500
25.....	1	61670-00	Piston Assy w/Seal & Spacer Kit

NOTE: For flat cap/backwash filter valve less items 12 thru 18.

Not Shown:

.....	1	11893	Cap, Injector, SS
.....	1	16221	Dispenser, Air
.....	2	15137	Screw, Hex Wsh Mach, 10-24 X 3/8

NOTE: For optimal seal life, the use of lubricants is not recommended.

For Service Assembly Numbers, See the Back of this Manual

SOFTENER & FILTER CONVERSION KITS

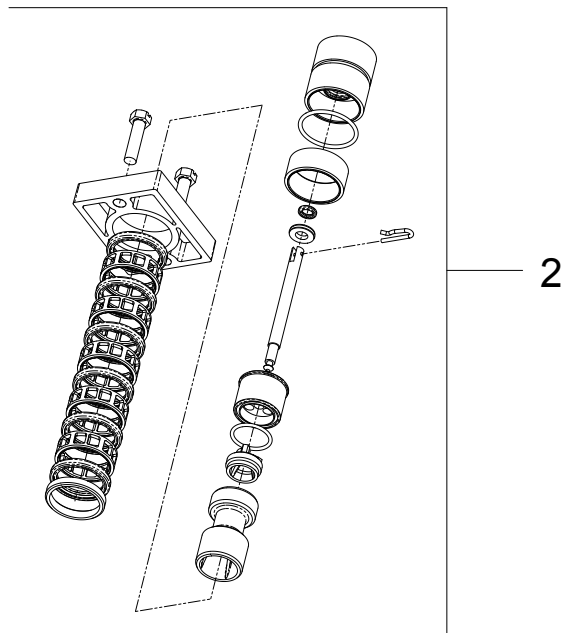
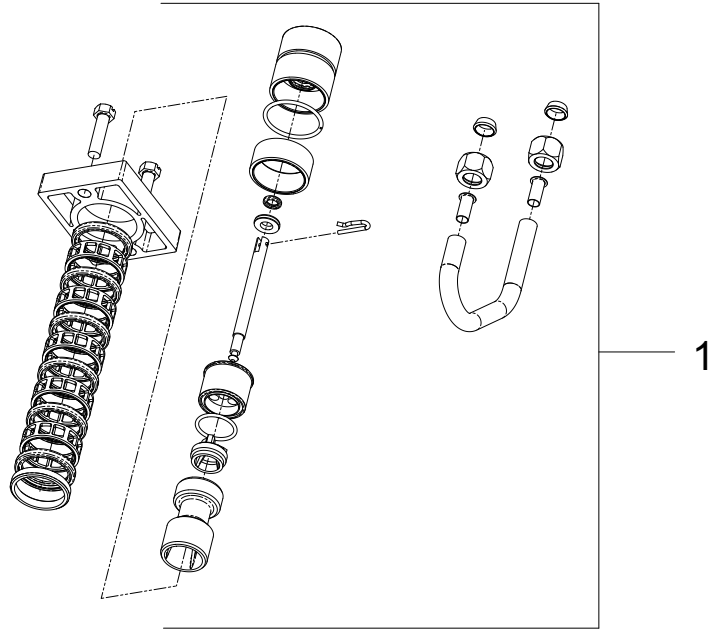

61671

Item No.	Part No.	Description
1.....	61671-10.....	Piston Assy, 1500 NHWBP 1600
2.....	61671-00.....	Piston Kit w/Seal & Spacer 2510 NHWBP Filter

NOTE: For optimal seal life, the use of lubricants is not recommended.

METER ASSEMBLY

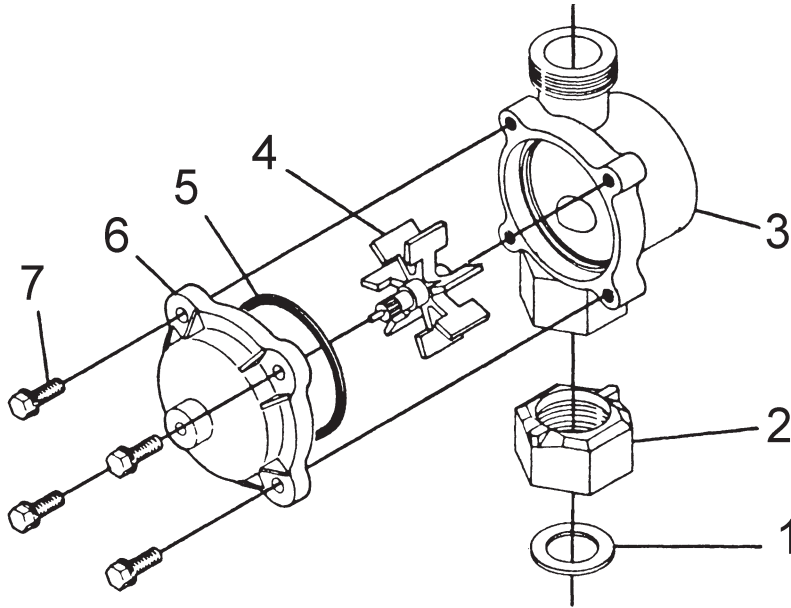

60397 Rev B

Item No.	QTY	Part No.	Description
1.....	1	11206	Gasket, Fitting
2.....	1	11207	Nut, Special, Quick Connect
3.....	1	13906.....	Body, Meter, 3/4"
4.....	1	13509.....	Impeller, Meter
5.....	1	13847	O-ring,-137, Std, Meter
6.....	1	14038.....	Meter Cap Assy, Std, Plastic
	1	15218.....	Meter Cap Assy, Std, Plastic, Brass Paddle
	1	15150.....	Meter Cap Assy, 3/4 to 2", Ext, Plastic Paddle
	1	15237.....	Meter Cap Assy, 3/4 to 2", Ext, Brass Paddle
7.....	4	12473.....	Screw, Hex Wsh, 10-24 X 5/8

Not Shown:

1	11205	Fitting, Tube Quick Connect
1	13882.....	Post, Meter Impeller

1600 BRINE SYSTEM

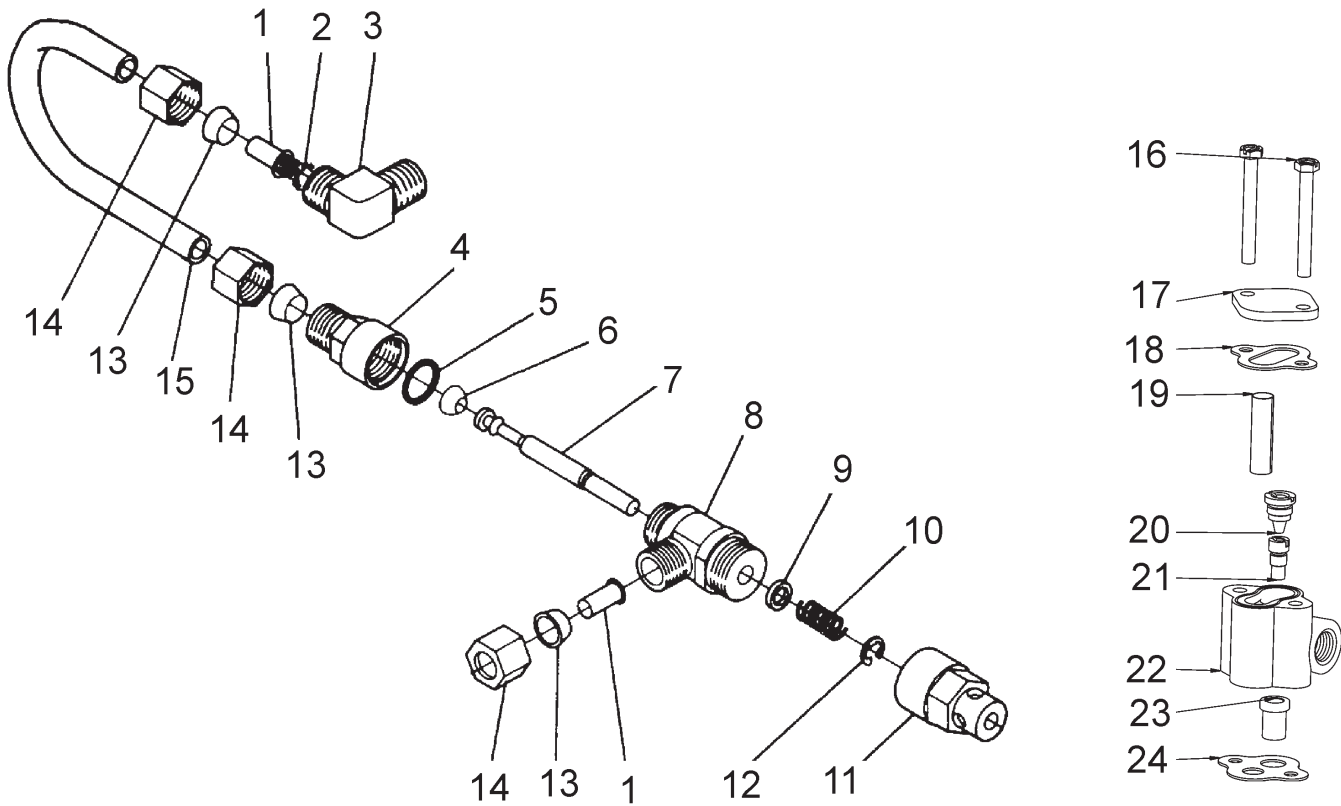

60029 Rev C

Item No.	QTY	Part No.	Description
1.....2	10332	Fitting, Insert, 3/8	
2.....1	12767	Screen, Brine	
3.....1	10328	Fitting, Elbow, 90 Deg. 1/4 PT x 3/8 Tube	
4.....1	60020-25	BLFC, .25 GPM, 1600	
4.....1	60020-50	BLFC, .50 GPM, 1600	
4.....1	60020-100	BLFC, 1.0 GPM, 1600	
5.....1	11982	O-Ring, -016	
6.....1	12626	Seat, Brine Valve	
7.....1	12552	Brine Valve Stem, 1600	
8.....1	12748	Brine Valve Body Assy, 1600 w/ Quad Ring	
9.....1	12550	Quad Ring, -009	
10.....1	10249	Spring, Brine Valve	
11.....1	11749	Guide, Brine Valve Stem	
12.....1	10250	Ring, Retaining	
13.....3	10330	Fitting, Sleeve, 3/8 Celcon	
14.....3	10329	Fitting, Tube, 3/8 Nut, Brass	
15.....1	16508-01	Tube, Brine Valve, 2850/1600	
1	12774	Tube, Brine Valve, 1500	
1	40027	Tube, Brine Valve, 2510	
1	15221	Tube, Brine Valve, 2750	
1	42184	Tube, Brine Valve, 2850s	
1	41683*	Tube, Brine Valve, UF, 1600/1650	

Item No.	QTY	Part No.	Description
16.....2	10692	Screw, Slot Hex Hd, 10 - 24X 18-8 SS	
17.....1	11893	Cap, Injector, SS	
18.....1	10229	Gasket, Injector Cap, 1600	
19.....1	10227	Screen, Injector	
20.....1	10913	Nozzle, Injector	
21.....1	10914	Throat, Injector	
22.....1	17776	Body, Injector, 1600	
1	17776-02*	Body, Injector, 1600 Upflow	
23.....1	16221	Disperser, Air	
24.....1	14805	Gasket, Injector Body, 1600/1700	

*Upflow Only

For Service Assembly Numbers, See the Back of this Manual

1650 BRINE SYSTEM

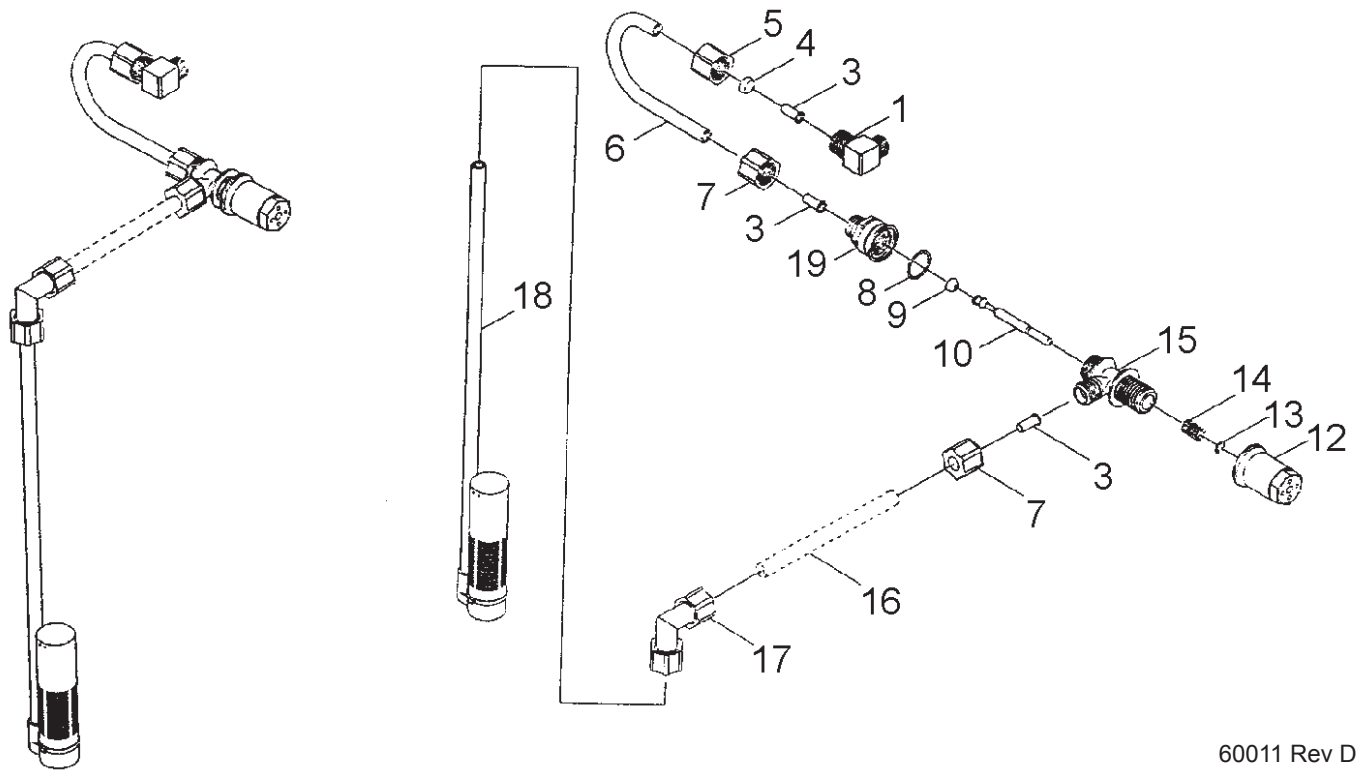

60011 Rev D

Item No.	QTY	Part No.	Description
60011 Brine Valve Assembly, Includes Items 3-15 (Less BLFC 60010-)			
1.....	1	10328.....	Elbow, 90 1/4 NPT x 3/8
3.....	3	10332.....	Insert, 3/8
4.....	1	10330.....	Sleeve, 3/8 Nut Brine
5.....	1	10329.....	Tube Fitting, 3/8 Nut Brine
6.....	1	12774.....	Tube, Brine Valve
7.....	2	19625.....	Assy., GFN Nut
8.....	1	16924.....	O-ring
9.....	1	12626.....	Seat, Brine Valve
10.....	1	12552.....	Brine Valve Stem, 1600
12.....	1	17906.....	Guide, Brine Valve Stem
13.....	1	10250.....	Retaining Ring
14.....	1	10249.....	Spring, Brine Valve
15.....	1	17884.....	Brine Valve Body Assy., Plastic
17.....	1	12794.....	Elbow, 3/8 Tube Poly, White
18.....	1	60002.....	#500 Air Check
19.....	1	60010-xx.....	BLFC Assy.

Item No.	QTY	Part No.	Description
60010-25 BLFC Assy. (Parts)			
1	1	17907.....	Housing
1	1	12128.....	.25 GPM Label
1	1	12094.....	.25 Flow Washer
1	1	12098.....	Retainer
60010-50 BLFC Assy. (Parts)			
1	1	17907.....	Housing
1	1	10759.....	.50 GPM Label
1	1	12095.....	.50 Flow Washer
1	1	12098.....	Retainer
60010-100 BLFC Assy. (Parts)			
1	1	17907.....	Housing
1	1	10760.....	1.0 GPM Label
1	1	12097.....	1.0 Flow Washer
1	1	12098.....	Retainer

For Service Assembly Numbers, See the Back of this Manual

2300 SAFETY BRINE VALVE

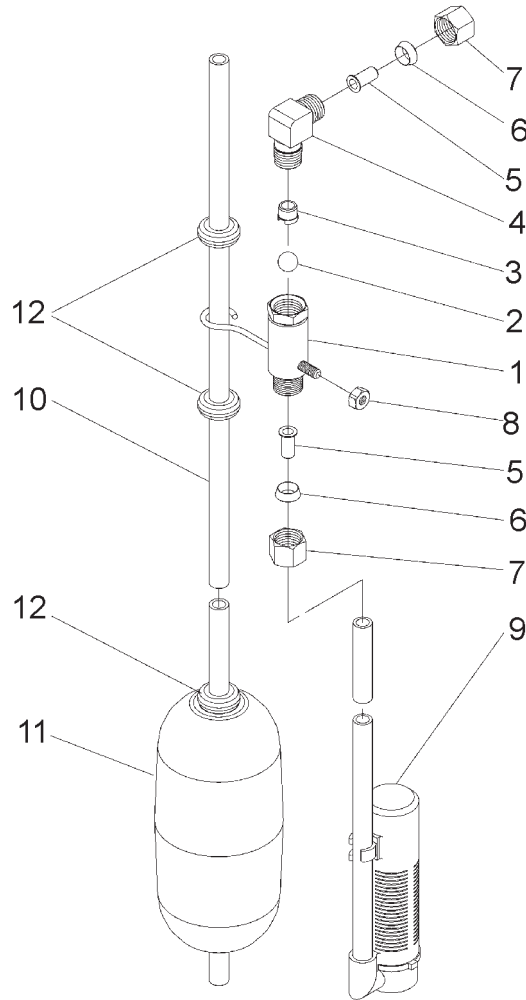

60027 Rev D

Item No.	QTY	Part No.	Description
1.....	1	60027-00.....	Safety Brine Valve, 2300, Less Elbow
	1	60027-FFA.....	Safety Brine Valve Body, 2300, Fitting Facing Arm
	1	60027-FFS.....	Safety Brine Valve Body, Fitting Facing Stud
2.....	1	10138.....	Ball, 3/8", Brass
3.....	1	11566.....	Ball Stop, Slow Fill
4.....	1	10328.....	Fitting, Elbow, 90 Deg. 1/4 NPT X 3/8 Tube
5.....	1	10332.....	Fitting, Insert, 3/8
6.....	1	10330.....	Fitting, Sleeve, 3/8 Celcon
7.....	1	10329.....	Fitting, Tube, 3/8 Nut, Brass
8.....	1	10186.....	Nut, Hex, 10-32
9.....	1	60002-34.....	Air Check, #500, 34" Long
	1	60003-34.....	Air Check, #500, HW, 34" Tube
10.....	1	10149.....	Rod, Float
11.....	1	10700w.....	Float Assy, White
	1	60028-30.....	Float Assy, 2300, 30", White
	1	60026-30SAN.....	Float Assy, 30", HW
12.....	3	10150.....	Grommet, .30 Dia

For Service Assembly Numbers, See the Back of this Manual

2310 SAFETY BRINE VALVE

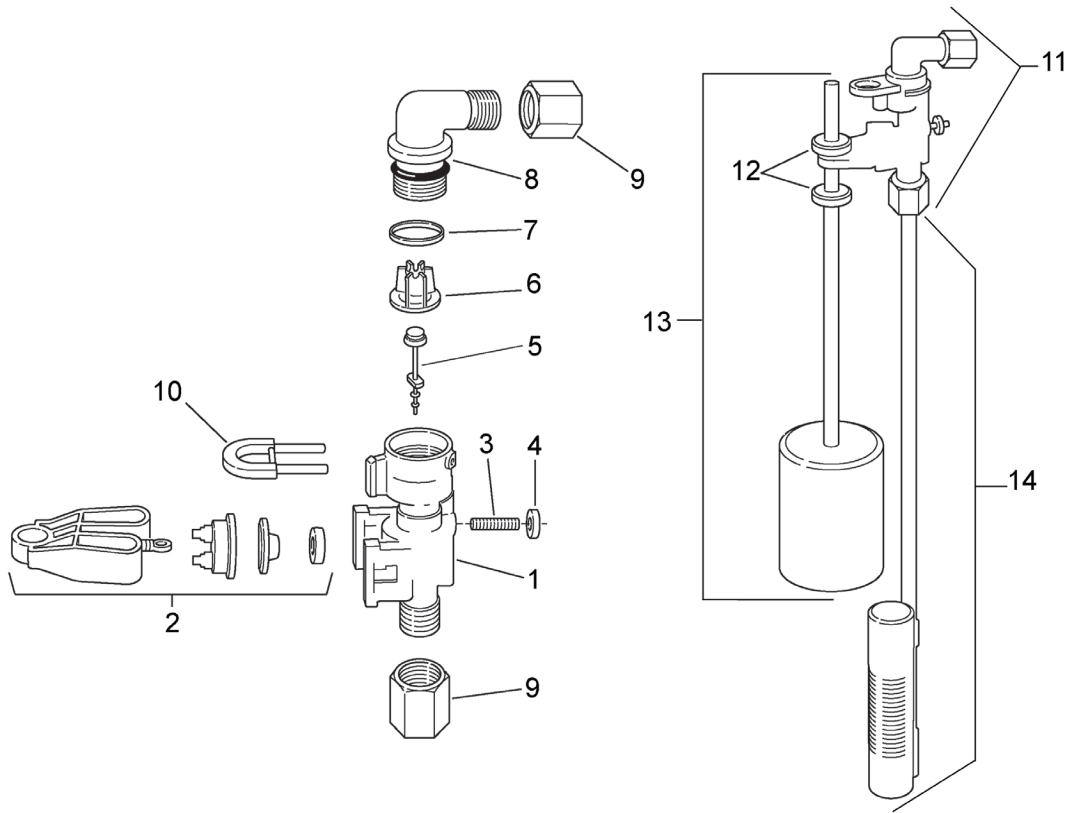

42112_REVA

Item No.	QTY	Part No.	Description
1.....	1	19645.....	Safety Brine Valve Body
2.....	1	19803.....	Safety Brine Valve Arm Assembly
3.....	1	19804.....	Stud, 10-24
4.....	1	19805.....	Nut, 10-24
5.....	1	19652-01.....	Poppet and Seal
6.....	1	19649.....	Flow Dispenser
7.....	1	11183.....	O-ring, 017
8.....	1	19647.....	Elbow, Safety Brine Valve
9.....	2	19625.....	Nut Assembly, 3/8
10.....	1	18312.....	Retaining Clip
11.....	1	60014.....	Safety Brine Valve, 2310 (includes items 1-10)
12.....	2	10150.....	Grommet (included with item 13)
13.....	1	60068-30.....	Float Assembly, 2310, w/30" Rod
14.....	1	60002-34.....	Air Check, #500, 34" long

For Service Assembly Numbers, See the Back of this Manual

SEAL & SPACER TOOLS & REPLACEMENT

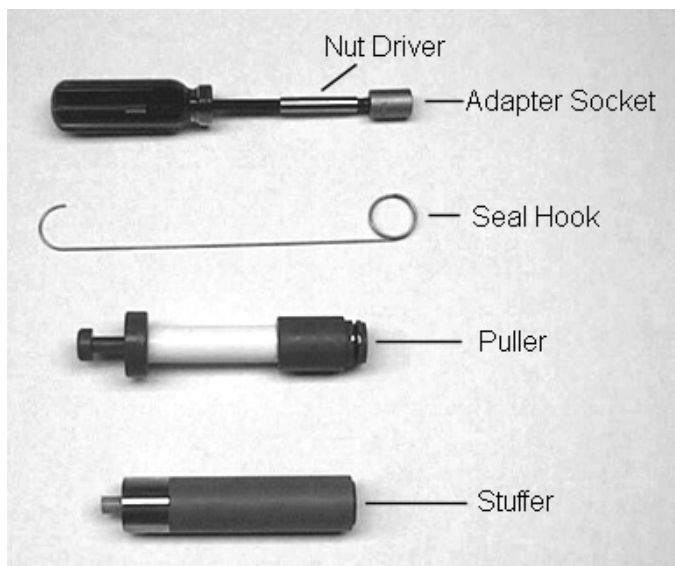

Figure 5

Tools Used in the Seal and Spacer Replacement

Description	Part No.
Nut Driver	12664
Socket Adapter	16906
Socket 7/16"	12665
Seal Hook	12874
Puller	13061
Stuffer	11098

NOTE: Photos shown are for reference only for replacing the seal and spacer. Actual valve may be different.

1. Turn off water supply to valve. Next, cycle valve to backwash position, then to service. Now remove electrical plug from outlet.
2. Remove control box cover.
3. Disconnect the brine line from the injector housing to the brine valve (if your unit has timed brine tank fill).
4. Remove the two capscrews that hold the back plate to the valve.
5. Grasp the back plate on both sides and slowly pull end plug and piston assembly out of the valve body (see Figure 6) and lay aside.

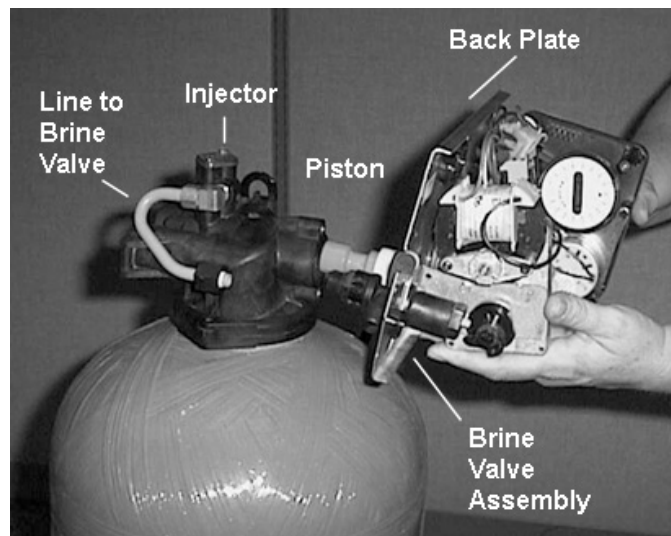

Figure 6

6. Remove the seal first using the wire hook with the finger loop (see Figure 7).

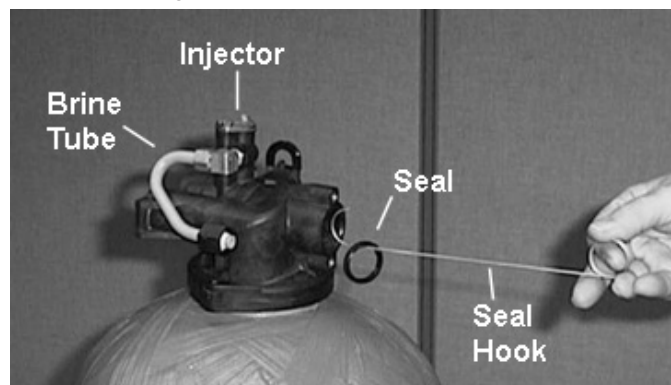

Figure 7

7. The spacer tool (use only for removing the spacers) has three retractable pins, retained by a rubber ring, at one end. They are retracted or pushed out by pulling or pushing the center button the opposite end.
8. Insert the pin end of the spacer tool into the valve body with the pins retracted (button pulled back). Push the tool tight against the spacer and push the button in, (see ?). When the button is pushed in, the pins are pushed out to engage the 1/4 dia. holes in the spacer. Remove the tool from the valve body. The spacer will be on the end. Pull the center button back, the pins will be retracted and the spacer can be removed from the spacer tool.

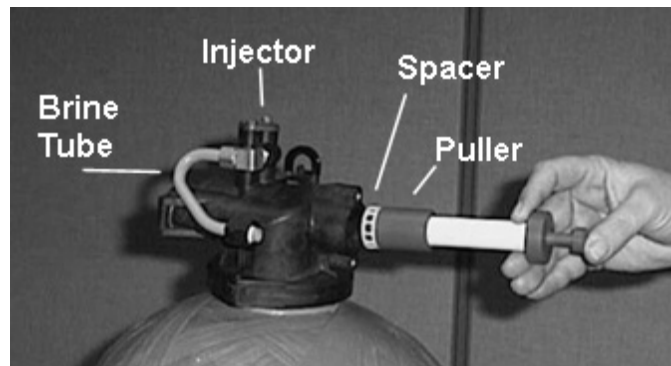

Figure 8

SEAL & SPACER TOOLS & REPLACEMENT *continued*

9. Alternately remove the remaining seals and spacers in accordance with steps No. 6 and 8.
10. The last or end spacer does not have any holes for the pins of the spacer tool to engage, therefore if the end spacer does not come out on the first try, try again using the wire hook with the finger loop.
11. To replace seals, spacers and end ring, use special tool with the brass sleeve on one end. This is a double-purpose tool (see ?). The male end acts as a pilot to hold the spacers as they are pushed into the valve body and the brass female end is used to insert the seals into the valve body.

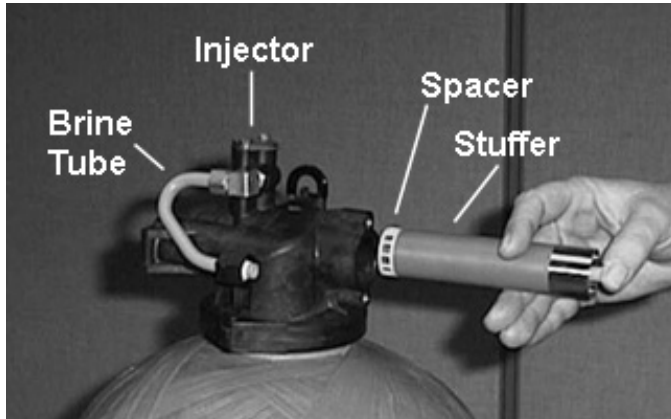

Figure 9

12. To restuff a valve body, first take the end ring (the plastic or brass ring without holes), then with your thumb press the button on the brass sleeve end. The large dia. inner portion is now exposed (see Figure 8). Place the end ring on this pilot with the lip on the end ring facing the tool. Push the tool into the valve body bore until it bottoms. While the tool is in the valve body, take a seal and press it into the inside diameter of the exposed brass female end.
13. Remove the tool, turn it end for end and insert it into the valve body bore. While holding the large dia. of the tool, slide it all the way into the valve body bore until it bottoms. Then push the center button to push the seal of the tool and leave it in place in the valve body.
14. Remove the tool from the valve body and push the center on the brass female end to expose the pilot on the opposite end. Place a spacer on this end and insert the spacer and tool into the valve.

GENERAL SERVICE HINTS FOR METER CONTROL

Problem: Softener delivers hard water

Reason: Reserve capacity has been exceeded.

Correction: Check salt dosage requirements and reset program wheel to provide additional reserve.

Reason: Program wheel is not rotating with meter output.

Correction: Pull cable out of meter cover and rotate manually. Program wheel must move without binding and clutch must give positive clicks when program wheel strikes regeneration stop. If it does not, replace timer.

Reason: Meter is not measuring flow.

Correction: Check meter with meter checker.

TROUBLESHOOTING

Problem	Cause	Correction
Water conditioner fails to regenerate.	Electrical service to unit has been interrupted	Assure permanent electrical service (check fuse, plug, pull chain, or switch)
	Timer is defective.	Replace timer.
	Power failure.	Reset time of day.
Hard water.	By-pass valve is open.	Close by-pass valve.
	No salt is in brine tank.	Add salt to brine tank and maintain salt level above water level.
	Injector screen plugged.	Clean injector screen.
	Insufficient water flowing into brine tank.	Check brine tank fill time and clean brine line flow control if plugged.
	Hot water tank hardness.	Repeated flushings of the hot water tank is required.
	Leak at distributor tube.	Make sure distributor tube is not cracked. Check O-ring and tube pilot.
	Internal valve leak.	Replace seals and spacers and/or piston.
Unit used too much salt.	Improper salt setting.	Check salt usage and salt setting.
	Excessive water in brine tank.	See "Excessive water in brine tank".
Loss of water pressure.	Iron buildup in line to water conditioner.	Clean line to water conditioner.
	Iron buildup in water conditioner.	Clean control and add mineral cleaner to mineral bed. Increase frequency of regeneration.
	Inlet of control plugged due to foreign material broken loose from pipes by recent work done on plumbing system.	Remove piston and clean control.
Loss of mineral through drain line.	Air in water system.	Assure that well system has proper air eliminator control. Check for dry well condition.
	Improperly sized drain line flow control.	Check for proper drain rate.
Iron in conditioned water.	Fouled mineral bed.	Check backwash, brine draw, and brine tank fill. Increase frequency of regeneration. Increase backwash time.
Excessive water in brine tank.	Plugged drain line flow control.	Clean flow control.
	Plugged injector system.	Clean injector and screen.
	Timer not cycling.	Replace timer.
	Foreign material in brine valve.	Replace brine valve seat and clean valve.
	Foreign material in brine line flow control.	Clean brine line flow control.
Softener fails to draw brine.	Drain line flow control is plugged.	Clean drain line flow control.
	Injector is plugged.	Clean injector
	Injector screen plugged.	Clean screen.
	Line pressure is too low.	Increase line pressure to 20 psi
	Internal control leak	Change seals, spacers, and piston assembly.
	Service adapter did not cycle.	Check drive motor and switches.
Control cycles continuously.	Misadjusted, broken, or shorted switch.	Determine if switch or timer is faulty and replace it, or replace complete power head.
Drain flows continuously.	Valve is not programming correctly.	Check timer program and positioning of control. Replace power head assembly if not positioning properly.
	Foreign material in control.	Remove power head assembly and inspect bore. Remove foreign material and check control in various regeneration positions.
	Internal control leak.	Replace seals and piston assembly.

WATER CONDITIONER FLOW DIAGRAMS

Service Position

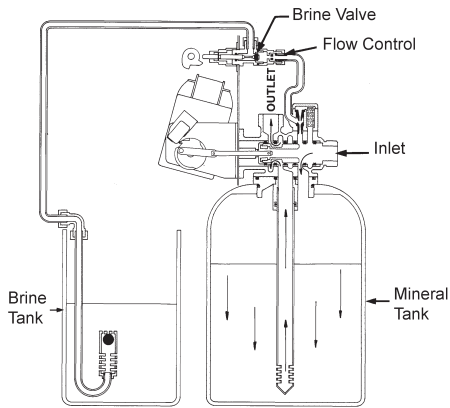

Slow Rinse Position

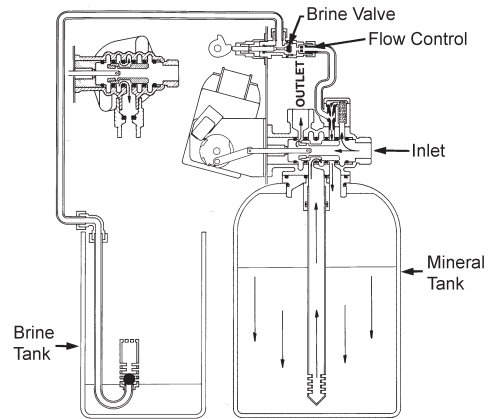

Backwash Position

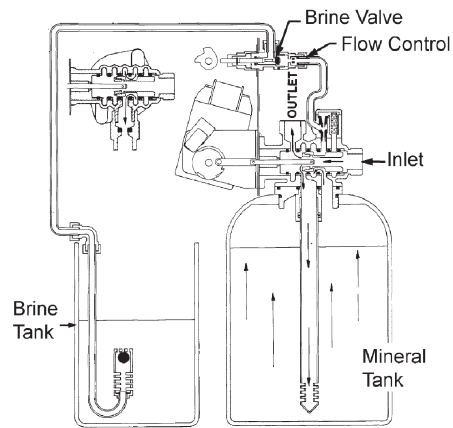

Rapid Rinse

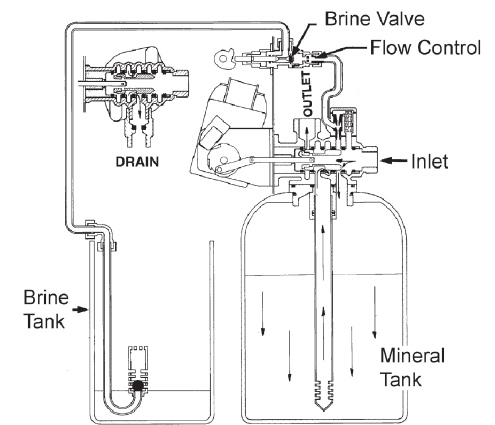

Brine Position

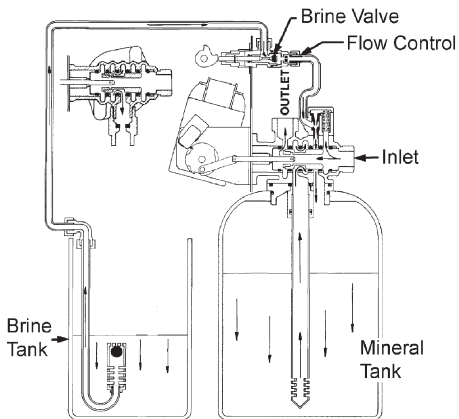

Brine Tank Fill Position

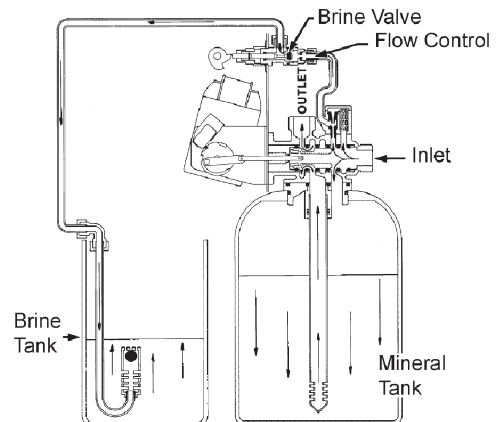

FLOW DATA & INJECTOR DRAW RATES

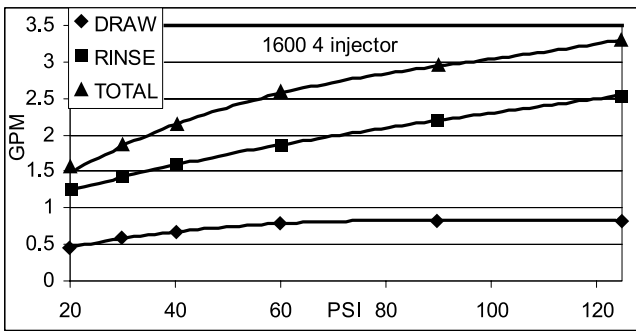
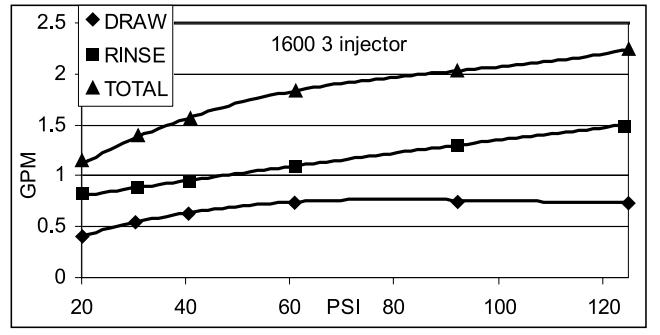
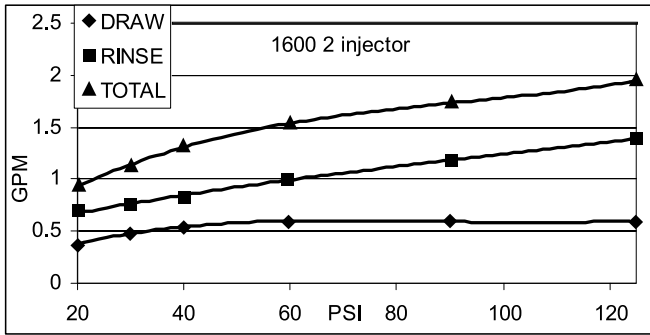
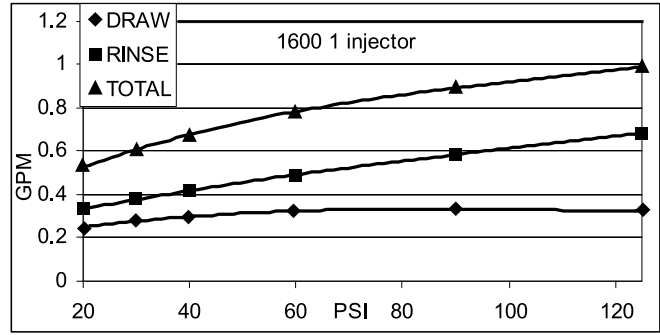
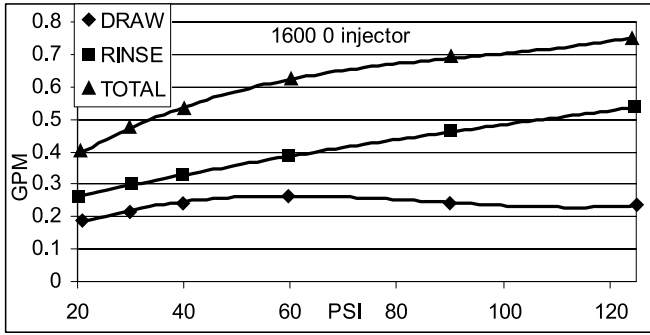

TR20391 Rev A

PLUMBING DIAGRAM: TYPICAL TOP MOUNTING INSTALLATION

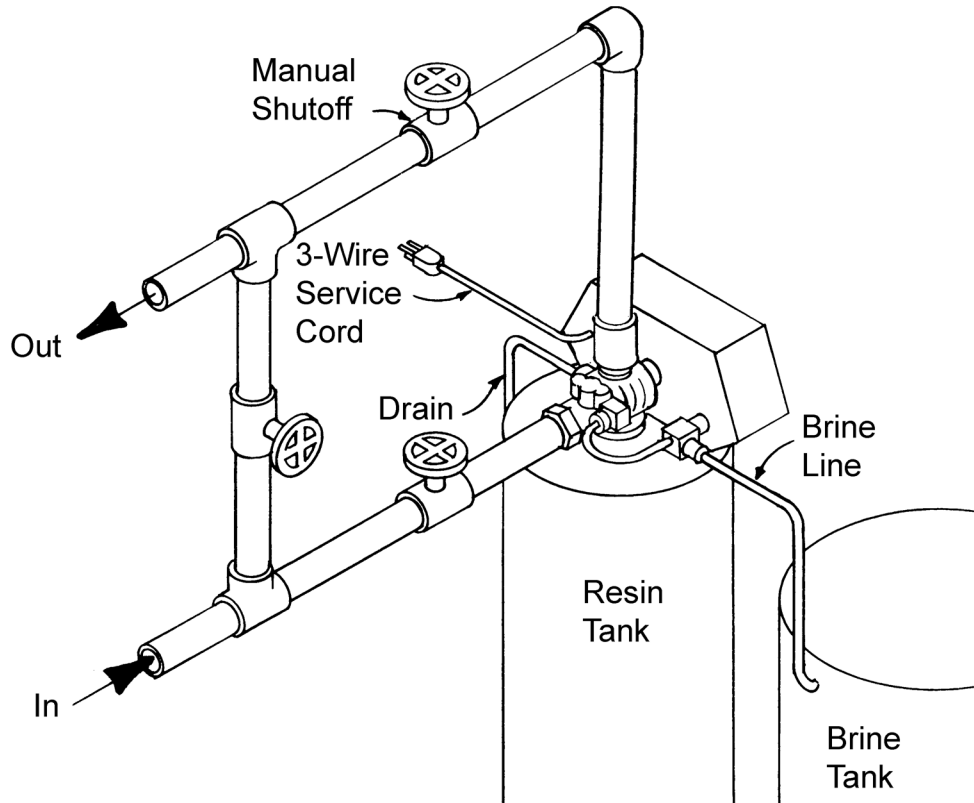

Typical Control Valve Information					
Tank Size Dia	Injector	Slow Rinse Rate (GPM) @ 40 PSI	Brine Draw Rate (SPM) @ 40 PSI	BLFC ¹	DLFC ²
6"	#0 Red	.31 GPM	.28 GPM	.5 GPM	1.2 GPM
7"	#0 Red	.31 GPM	.28 GPM	.5 GPM	1.2 GPM
8"	#1 White	.45 GPM	.38 GPM	.5 GPM	1.5 GPM
9"	#1 White	.45 GPM	.38 GPM	.5 GPM	2.0 GPM
10"	#1 White	.45 GPM	.38 GPM	.5 GPM	2.4 GPM
12"	#2 Blue	.84 GPM	.56 GPM	1.0 GPM	3.5 GPM
13"	#2 Blue	.84 GPM	.56 GPM	1.0 GPM	4.0 GPM
14"	#3 Yellow	1.0 GPM	.63 GPM	1.0 GPM	5.0 GPM
16"	#3 Yellow	1.0 GPM	.63 GPM	1.0 GPM	7.0 GPM

NOTE: Due to varying water conditions, tank sizes, and water pressures, the above settings should only be used as a guideline.

¹BLFC (Brine Line Flow Control) refill rate for filling brine tank

²DLFC (Drain Line Flow Control) backwash and rapid rinse flow rates

WIRING DIAGRAM

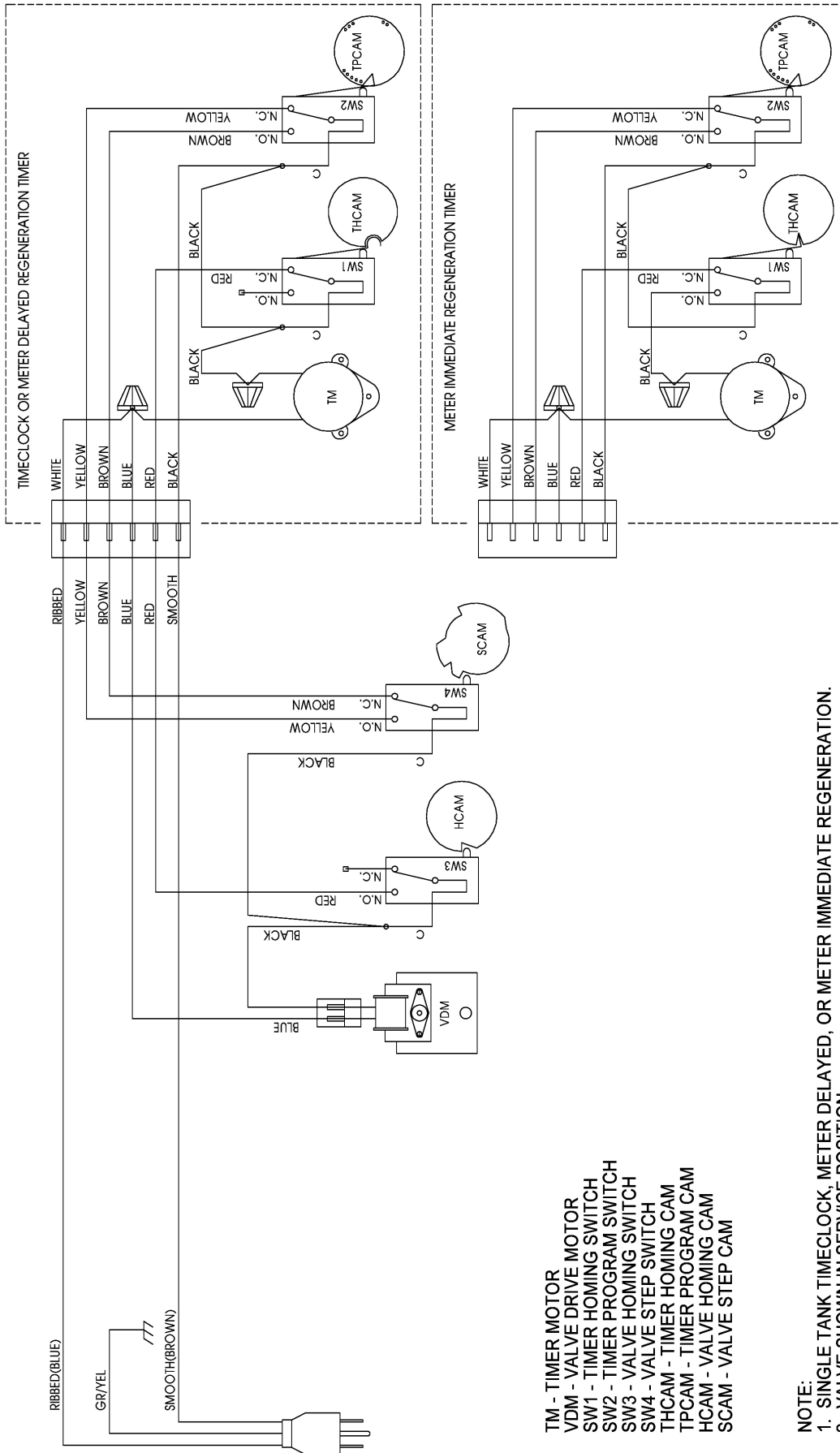

- TM - TIMER MOTOR
- VDM - VALVE DRIVE MOTOR
- SW1 - TIMER HOMING SWITCH
- SW2 - TIMER PROGRAM SWITCH
- SW3 - VALVE HOMING SWITCH
- SW4 - VALVE STEP SWITCH
- THCAM - TIMER HOMING CAM
- TPCAM - TIMER PROGRAM CAM
- HCAM - VALVE HOMING CAM
- SCAM - VALVE STEP CAM

NOTE:
 1. SINGLE TANK TIMECLOCK, METER DELAYED, OR METER IMMEDIATE REGENERATION.
 2. VALVE SHOWN IN SERVICE POSITION.

SERVICE ASSEMBLIES

24 Hour Gear

40096-02	Dial 2AM Regen Assy, Black
40096-24	Dial 12AM Regen Assy, Black
60519-02	Gear Assy, 3200, 24 Hour 2 Times/Day
60519-03	Gear Assy, 3200, 24 Hour 3 Times/Day
60519-04	Gear Assy, 3200, 24 Hour 4 Times/Day
60519-06	Gear Assy, 3200, 24 Hour (12:00) 6 Times/Day

BLFC (Brine Line Flow Controls):

60020-25	BLFC .25 GPM
60020-50	BLFC .50 GPM
60020-100	BLFC 1.0 GPM
60010-50	BLFC, 1650, .50 GPM, Plastic
60010-100	BLFC, 1650, 1.0 GPM, Plastic

Brine Valves:

10249	Brine Valve Spring
10250	Retaining Ring
10329	3/8" Brass Nut
10330	3/8" Ferrule
10332	3/8" Sleeve
11749	B/V Stem Guide
11982	O-ring Brine Valve
12552	1600 Brine Valve Stem
12626	Shut-Off Valve Seat
12748	Brine Valve Body
12550	Quad Ring
60011-010	Brine Valve, 1650, Short Stem, .25 GPM, Less Tube
60011-030	Brine Valve, 1650, Short Stem, 1.0 GPM, Less Tube
60029-010	Brine Valve, 1600, Short Stem, .25 GPM
60029-010	Brine Valve, 1600, Short Stem, .50 GPM
60029-030	Brine Valve, 1600, Short Stem, 1.0 GPM

Cams:

12777	Cam, Shut-Off Valve
60160-15	Drive Cam Assy, STF, Blue

Drain Line Flow Controls (DLFC):

60704-00	DLFC, Brass, Blank
60704-06	DLFC, Brass, .60 GPM
60704-08	DLFC, Brass, .80 GPM
60704-10	DLFC, Brass, 1.0 GPM
60704-12	DLFC, Brass, 1.2 GPM
60704-13	DLFC, Brass, 1.3 GPM
60704-15	DLFC, Brass, 1.5 GPM
60704-17	DLFC, Brass, 1.7 GPM
60704-20	DLFC, Brass, 2.0 GPM
60704-24	DLFC, Brass, 2.4 GPM
60704-30	DLFC, Brass, 3.0 GPM
60704-35	DLFC, Brass, 3.5 GPM
60704-40	DLFC, Brass, 4.0 GPM
60704-45	DLFC, Brass, 4.5 GPM
60704-50	DLFC, Brass, 5.0 GPM
60704-60	DLFC, Brass, 6.0 GPM
60704-70	DLFC, Brass, 7.0 GPM
60705-00	DLFC, Plastic, Blank
60705-06	DLFC, Plastic, .60 GPM
60705-08	DLFC, Plastic, .80 GPM
60705-10	DLFC, Plastic, 1.0 GPM
60705-12	DLFC, Plastic, 1.2 GPM
60705-13	DLFC, Plastic, 1.3 GPM
60705-15	DLFC, Plastic, 1.5 GPM
60705-17	DLFC, Plastic, 1.7 GPM
60705-20	DLFC, Plastic, 2.0 GPM
60705-24	DLFC, Plastic, 2.4 GPM
60705-30	DLFC, Plastic, 3.0 GPM
60705-35	DLFC, Plastic, 3.5 GPM
60705-40	DLFC, Plastic, 4.0 GPM
60705-45	DLFC, Plastic, 4.5 GPM
60705-50	DLFC, Plastic, 5.0 GPM
60705-60	DLFC, Plastic, 6.0 GPM
60705-70	DLFC, Plastic, 7.0 GPM

Drives:

60050-21	2750 Drive Assy, STF 120V
10218	Micro Switch
10338	Pin, Roll 3/32 x 7/8
41543	Motor Drive, 115V, 50/60HZ
40400	Harness, Drive, Designer/Environmental
14923	Screw, Pan HD Mach 4-40 x 1
17904	Bushing, Heyco 1/2
12777	Cam, Shut-off Valve

Injectors:

60480-XX	1600 Injector Assembly
10227	Injector Screen
11893	Injector Cap
10229	Injector Cover Gasket
10328	90° Elbow 1/4" NPT x 3/8 Tube
10692	Screw
10913	Injector Nozzle
10914	Injector Throat
11475	Injector Body Gasket
16221	Dispenser, Air
17776	Injector Body

SERVICE ASSEMBLIES *continued*

Meters:

60387.....	Meter Assy, 3/4" InIn,NPSM/BSP, Ext, Brs Bdy, Pdl
60397.....	Meter Assy, 3/4" InIn, NPT, Std Brass Body, Paddle
60398.....	Meter Assy, 3/4" InIn, NPT, Ext Brass Body, Paddle

Pistons:

61670-00	Piston Assy w/Seal & Spacer Kit, 2510 Piston, 1500
61670-01	Piston Assy w/Seal & Spacer Kit2510 Piston, NHWBP, 1500
60091-HF.....	Piston Assy, 2750, Hot Water

Program Wheels:

60405-10	Program Wheel w/3/4" Std Label Set @ 21
60405-15	Program Wheel w/3/4" Std Label w/People Label Set @ 21

Sales & Service Aids:

15856.....	Literature, 1500, S/Manual
40728.....	Literature, 1500, Spec Sheet

Seal & Spacers:

60121.....	Seal and Spacer Kit
60122.....	Seal and Spacer Kit, Hot Water
10545.....	Seal, Piston, Hot Water
10757B	End Spacer, Hot Water
16589.....	Spacer, Hot Water

Skipper Wheels:

14860.....	Skipper Wheel Assy, 7 Day
14381.....	Skipper Wheel Assy, 12 Day

